

FLOJET

Duplex Diaphragm Design 2100 Series Automatic Water System Pump & Shower Drain • General Purpose Pump

FEATURES

- Self-Priming
- Dry Running
- Automatic Operation
- Models Meet U.S.C.G. Electrical Standards

SPECIFICATIONS

Motor: Permanent Magnet, Ball Bearing. CE Models are fully suppressed.

Pump: Two chamber diaphragm design; Self-priming up to 6 ft. suction lift; Pump able to run dry without damage.

Port: Pump housing inlet and outlet are 3/8" NPT female threads.

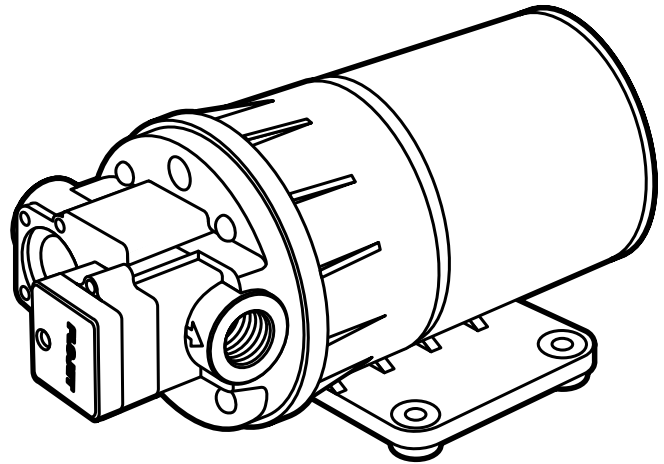

Model 2100 Series



Pump Series	Dimensions - Inches (mm)			Weight lb. (kg)
	Height	Width	Length	
2100-XXX	3.75 (95)	3.25 (83)	8.2 (208)	3.3 (1.5)

MODEL*	VOLTS	AMP DRAW @ 10 psi (0.7 bar)	FUSE AMPS	FLOW GPM (l/min)	PRESSURE SWITCH PSI (BAR)	
					ON	OFF
2100-12	12V dc	2.5	7	2.3 (8.7)	15 (1)	30 (2)
2100-694**	12V dc	2.5	7	2.3 (8.7)	No Pressure Switch	
2100-740	24V dc	1.5	5	2.3 (8.7)	15 (1)	30 (2)
2100-750	12V dc	2.5	7	2.3 (8.7)	15 (1)	30 (2)

*CE fully suppressed models are identified by a prefix "R" and a CE mark on the label. (i.e. R2100-740)
Self Declaration Of Conformance (SDOC) is available upon request.

**Shower Drain Model only, does not include port connectors, see Accessories to order connectors.

OPERATION FOR WATER SYSTEM PUMPS

The FLOJET 2100 series pumps are automatic demand pumps. They will automatically turn on when a fixture is opened and turn off when all fixtures are closed.

When starting from a completely drained system allow time for the demand pump to fill the hot water tank. After refilling the tank the pump is reprimed by opening a fixture. Allow air to vent and close fixture when water flow is steady. Faucet strainers and aerators should be cleaned regularly.

OPERATION FOR THE SHOWER DRAIN PUMP

Model 2100-694 is a utility/shower drain pump. The pump will not turn off automatically. Your shower drain pump is designed to self-prime up to 6 feet suction lift (vertical distance from shower pan to pump inlet). It is recommended you utilize a "lighted" on-off switch so that pump is turned off when not in use. The pump is able to run dry (no liquid) for extended periods with no damage to the pump, however this could cause needless battery drain.

AUTOMATIC WATER SYSTEM INSTALLATION

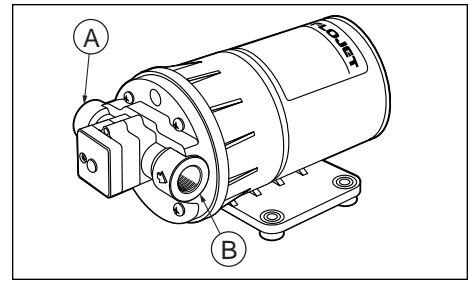
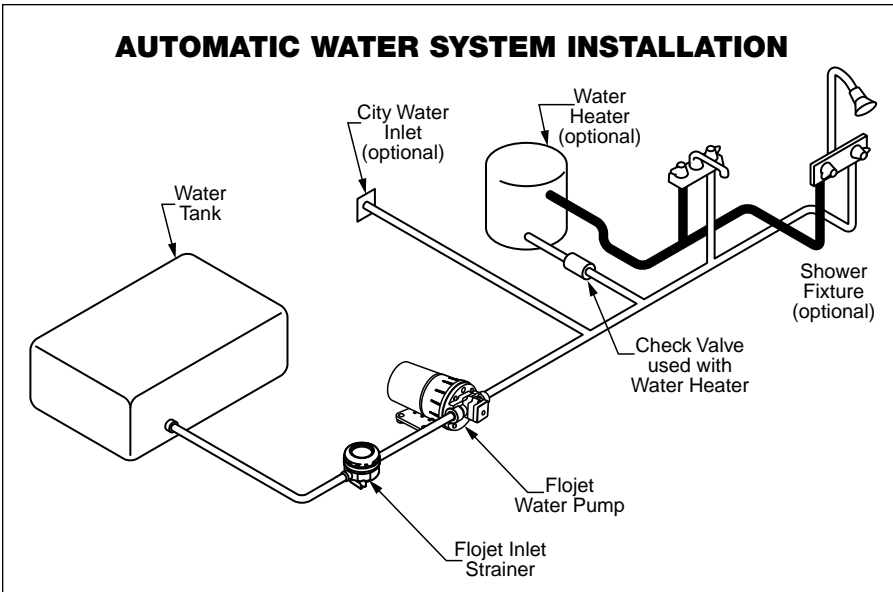

SHOWER DRAIN INSTALLATION

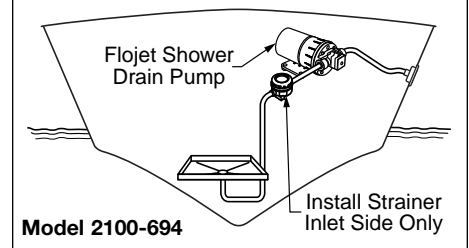

INSTALLATION

STEP 1

Remove shipping plugs from pump ports. Some water from factory testing may spill out.

STEP 2

Install inlet A and discharge B port connectors.

STEP 3

Insert rubber mounting grommets onto base plate.

STEP 4

Mount pump vertically, with pump head down or horizontally in an accessible location. Do not compress grommets.

STEP 5

Use 1/2" or 3/8" I.D. flexible hose (preferably braided or reinforced). Use hose clamps on the slip-on barb hose connectors.

STEP 6

Install no less than 3/8" I.D. hose for feed lines to fixtures. Use high pressure hose on all city water lines.

STEP 7

Install a Flojet strainer in an accessible location (for inspection and cleaning) between the tank and pump inlet. This strainer or equivalent is required for pump warranty to be valid.

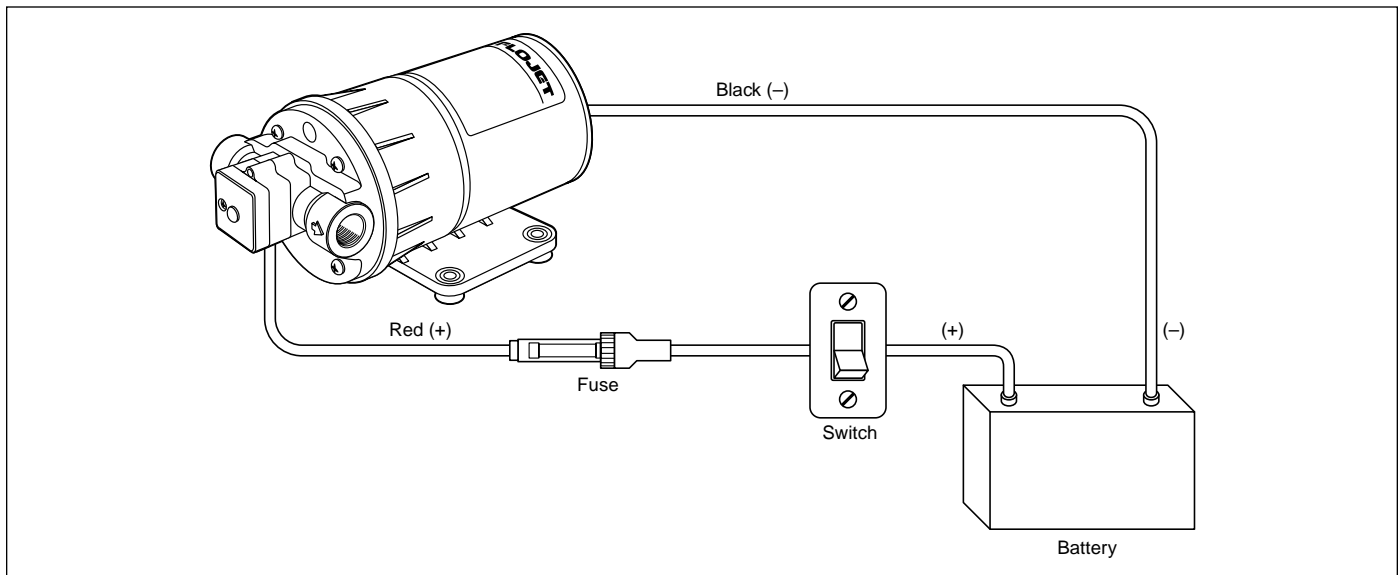

WIRING

In an easily accessible location, install a switch to control electricity to the pump. Turn the pump off when not in use for extended periods, or when tank is out of water.

A 7 amp. fuse should be installed in the positive line with the pump being its only load. (24V model, use 5A fuse).

Wire size based on total wire length.

0 - 20 ft.	#16 AWG
20 - 50 ft.	#14 AWG
50 - 80 ft.	#12 AWG

TROUBLESHOOTING

WARNING: BEFORE SERVICING PUMP, TURN OFF PUMP AND DRAIN WATER FROM SYSTEM!!

Pulsating Flow - Pump cycles on and off

- Restricted pump delivery. Check discharge lines, fittings and valves for clogging or undersizing.

Failure to Prime - Motor operates, but no pump discharge

- Restricted intake or discharge line. Open all fixtures, check for “jammed” check valve poppets and clean clogged lines
- Air leak in intake line
- Punctured pump diaphragm
- Defective pump check valve
- Crack in pump housing
- Debris in check valves

Motor Falls To Turn On

- Pump switch in off position
- Loose wiring connection
- Blown fuse

- Pressure switch failure
- Defective motor

Pump Falls to Turn Off After All Fixtures Are Closed

- Empty water tank
- Insufficient voltage to pump (low battery)
- Discharge line leak
- Defective pressure switch
- Punctured pump diaphragm

Low Flow and Pressure

- Air leak at pump intake
- Accumulation of debris inside pump and plumbing
- Worn pump bearing (excessive noise)
- Punctured pump diaphragm
- Defective motor

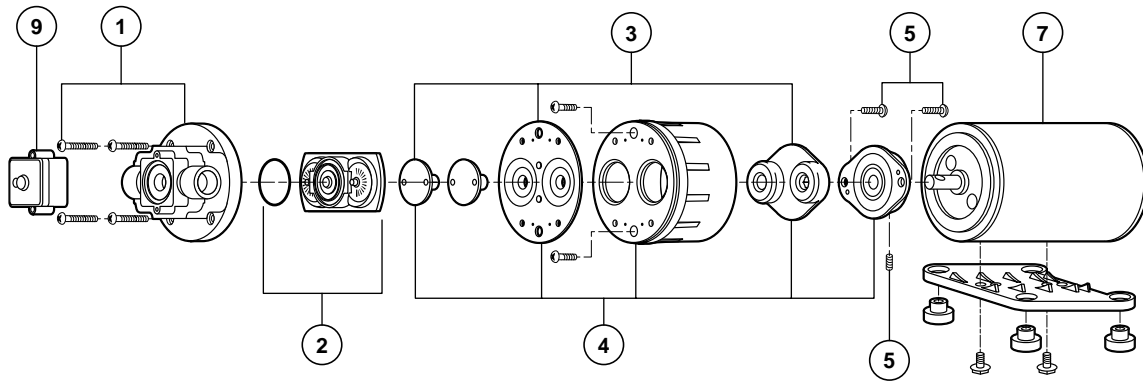

Quite often when a pump is worn or defective the one failed component has overburdened others. To avoid frequent aggravating repairs, Flojet offers service kit assemblies making repairs as quick and easy as possible.

DISASSEMBLE

Pressure Switch

1. Remove switch (9). Disconnect switch wires.
2. Loosen four pump head screws and carefully remove upper housing assembly (1)

Upper Housing

- Follow steps 1 and 2
3. Inspect check valve (2) for debris
4. Reassemble new upper housing (1)

Check Valve Assembly

- Follow steps 1 and 2
3. Replace check valve (2)
4. Reassemble upper housing (1)

Lower Housing, Diaphragm, Motor

- Follow steps 1 and 2, then remove 2 recessed screws.
3. Rotate lower housing (4) so drain notch opening on lower housing near baseplate exposes set screw which holds bearing housing to shaft.
4. Loosen this set screw by inserting wrench 1/8" Allen wrench into drain notch opening. Then, slide lower housing (4) off motor shaft.

Diaphragm Cont'd

5. Loosen two cam piston screws with Phillips head screw driver and pull apart cam from inner pistons. (Pistons should always be replaced when a new diaphragm is installed.)

Motor Cont'd

5. Replace Motor

REASSEMBLE

Motor

1. Reassemble lower housing assembly (4) to motor. (Follow steps 4 to 10.)

Diaphragm

2. Lower housing is assembled with:
 - Flat side of diaphragm and outer pistons facing motor
 - Hex stem of inner pistons must be aligned into hex holes in outer pistons (4).
 - Outer pistons must be aligned with alignment slots on cam assembly making sure screw holes align in cam assembly, otherwise diaphragm will leak.
3. Tighten cam piston screws partially, center piston in diaphragm, then tighten screws securely (18 in. lbs. torque)

Lower Housing

4. Reassemble lower housing assembly (4) to motor.
5. Retighten set screw securely. Set screw head must be positioned facing motor covering seam (indentation). (Positioning of this screw is critical to avoid misalignment and subsequent diaphragm damage.)

Upper Housing, Check Valve

6. Reassemble upper housing (1)
7. Properly seat O-Ring in check valve assembly (2) and check if ferrules and screen are in place on upper housing (1)
8. Install check valve (2) into upper housing (1) and push in.
9. Assemble on to lower housing (4), align 4 screws on to motor by rotating lower housing (4) if necessary.
10. Tighten screws evenly to 30 in. lbs. torque.

Pressure Switch

1. Place switch against front of pump (9), insert screws and take care not to cross thread or strip out threads in housing.
2. Reconnect wires.

PUMP SERVICE PARTS

KEY	DESCRIPTION	MODEL #			
		2100-12	2100-694	2100-740	2100-750
7	Motor 12V	2009-004C	2009-004C		2009-004C
7	Motor 24 V			2019-001A	
	Pump Service Kit	21046-057	21046-057	21046-057	
	Pump Service Kit				21046-121
9	Pressure Switch Assy.	2095-105		2095-105	2095-105

*Service Kit Pump Service Kit includes item #2, 3, 5 and 6.

**CE fully suppressed motors are available, order R2009-004C or R201 9-001 A respectively.

ACCESSORIES

PORT CONNECTORS (NYLON)

Part Number	Pump Connection	Plumbing Connection
91010-001	3/8" NPT (m)	X 3/8" Hose Barb 90° Elbow
91010-002	3/8" NPT (m)	X 3/8" Hose Barb Straight
91010-005	3/8" NPT (m)	X 1/2" Hose Bar 90° Elbow
91010-006	3/8" NPT (m)	X 1/2" Hose Barb Straight
91010-056	3/8" NPT (m)	X 1/2" Male QEST Straight

STRAINERS

Pump Series	Strainer Number	Inlet	Outlet	Screen
2100-XXX	1740-003	3/4 Barb	3/4 Barb	40 Mesh
	1740-002	1/2 Barb	1/2 Barb	40 Mesh
	1740-004	1/2 M Qest	1/2 M Qest	40 Mesh

WARRANTY

FLOJET warrants this product to be free of defects in material and/or workmanship for a period of one year after purchase by the customer from FLOJET. During this one year warranty period, FLOJET will at its option, at no charge to the customer, repair or replace this product if found defective, with a new or reconditioned product, but not to include costs of removal or installation. This is only an overview of our limited warranty. If you would like a copy of our warranty, please call or write FLOJET.

RETURN PROCEDURE

Prior to returning any product to FLOJET, call customer service for an authorization number. This number must be written on the outside of the shipping- package. Place a note inside the package with an explanation regarding the reason for return as well as the authorization number. Include your name, address and phone number.

Flojet



ITT Industries
Engineered for life

U.S.A.
Flojet
20 Icon
Foothill Ranch, CA 92610-3000
Tel: (949) 859-4945
Fax: (949) 859-1153

UNITED KINGDOM
Jabsco/Flojet
Bingley Road, Hoddesdon
Hertfordshire EN11 OBU
Tel: +44 (0) 1992 450145
Fax: +44 (0) 1992 467132

CANADA
Fluid Products Canada
55 Royal Road
Guelph, Ontario N1H 1T1
Tel: (519) 821-1900
Fax: (519) 821-2569

JAPAN
NHK Jabsco Company Ltd.
3-21-10, Shin-Yokohama
Kohoku-Ku, Yokohama, 222
Tel: 045-475-8906
Fax: 045-475-8908

GERMANY
Jabsco GmbH
Oststrasse 28
22844 Norderstedt
Tel: +49-40-53 53 73-0
Fax: +49-40-53 53 73-11