



Electric Bag-in-Box Pump

Application

- Designed for dispensing wine, juice, teas or liquor from Bag-in-Box
- Ideal for under counter installation



Special Features

- Quick, simple, safe installation
- Compact size for easy mounting
- Sealed box unit with one piece moulded plug and power cord
- Safety timer turns the pump off automatically after 3 minutes
- Easily accessible manual on/off switch to restart the pump
- Self priming
- Able to run dry without damage
- Quiet



Specifications

Model Number:	FSP0002A
Pump Design:	Positive displacement double diaphragm
Voltage:	230VAC, 50/60Hz
Approvals:	IPX4 rated enclosure NSF listed, CE
Wetted Pump Parts:	
Housing	Polypropylene
Elastomers	EPDM & Santoprene®
Check Valve Spring	Stainless Steel
Inlet Hose:	9.5mm (3/8") beverage tubing
Outlet Port:	9.5mm (3/8") John Guest
Liquid Temperature:	43°C maximum
Net Weight:	3 Kgs
Dimensions:	Length - 21cm (8.26") Width - 15cm (5.91") Height - 7.5cm (2.95")

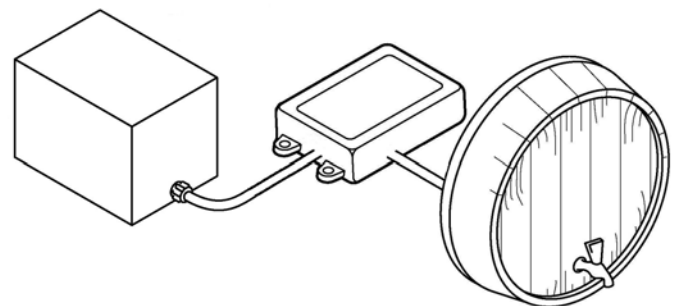

Flojet



ITT Industries

USA

Flojet
20 Icon
Foothill Ranch
CA 92610
USA
Tel - +1 949 859 4945
Fax - +1 949 859 1254

UK

Flojet Europe
Unit 1, Avant Business Centre
Denbigh West Industrial Estate
Milton Keynes
MK1 1DL
England
Tel - +44 1908 370088
Fax - +44 1908 373731