

### Installation & Service Information

#### Description

FLOJET Industrial LF Pumps are designed for a wide range of applications and are constructed from a selection of materials suitable for handling a broad range of chemicals. The LF series of diaphragm pumps are self-priming and can be run dry without harm. They are intended for intermittent duty cycles but can be run continuously for short periods of time. The higher the duty cycle the shorter the expected life of the pump.

Typical pump uses are liquid transfer, spraying, circulation, filtration and dispensing.

#### Operation

To start and prime the pump, the discharge line must be open allowing trapped air to escape thus avoiding the potential of airlock. The pressure switch will shut off the pump automatically when the discharge valve is closed and the pressure has risen to the switch OFF set point. The pressure switch will restart the pump when a valve is opened and the discharge line pressure drops to the ON set point of the pressure switch.

#### Demand Operation (intermittent duty)

Demand Operation is considered an "intermittent duty" application. The maximum intermittent duty cycle is that which will cause the motor to reach its maximum thermal limits. Once the maximum thermal limit is reached, the motor must be allowed to settle to a lower temperature ideally being ambient before resuming operation. Running the pump at or near the maximum thermal limit for extended period of time will shorten the life of the pump and may result in immediate pump failure.

#### Bypass Operation (if equipped)

Models equipped with an external bypass system are designed to pump at high pressures while at low or high flow rates. Models equipped with a bypass only will continue to run until the power is manually turned off.

The LF pumps are not recommended for continuous duty service due to limited motor brush life. Operation at lower pressures and temperatures, however, will extend overall pump service life.

#### Mounting

The FLOJET LF Series pumps are self-priming. Vertical prime may vary depending on the fluid viscosity, suction tube size, foot valve and pump configuration. The pump should be mounted in a dry and adequately ventilated area. If mounted within an enclosure, provisions to cool the motor may be necessary.

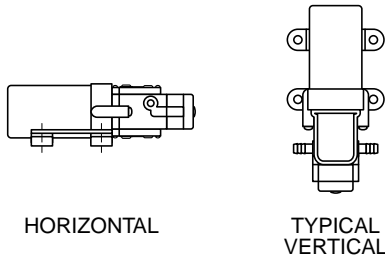

#### Preventative Maintenance Tips

If pumping a liquid other than water the pump should be flushed with water (if applicable) after each use.

Before freezing conditions occur, the pump must be liquid free or winterized with proper anti-freezing chemicals.

If mounting the pump in an outdoor environment the pump should be shielded from water, dust, sunlight and wash down spray.

Do not assume chemical compatibility. If the fluid is improperly matched to the pumps elastomers, the pump may fail to prime, have low pressures or the pressure switch may not shut off.

#### Plumbing

Use flexible hose of the correct pressure rating that is compatible with the fluid to be pumped. Tubing should be a minimum of 3/8" (9.5 mm) ID and at least 20 inches (508 mm) in length to avoid excess stress on the pump ports. Do not crimp or kink the tubing.

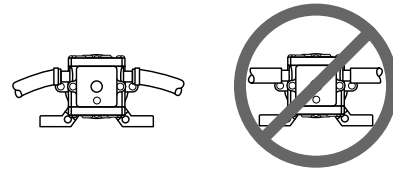

FLEXIBLE HOSE

RIGID PIPE

The use of check valves in the plumbing system could interfere with the priming ability of the pump. If a check valve is installed in the plumbing it must have a cracking pressure of no more than 2 PSI (.14 bar).

Use of a minimum 40-mesh strainer or filter in the pump inlet line will prevent foreign debris from entering the system. Failures due to foreign debris entering the pump will not be covered under the limited warranty.



### WARNING



#### Risk of an electrical shock!

When wiring electrically driven pumps, follow all electrical and safety codes, as well as the most recent National Electrical Code (NEC) and the Occupational Safety and Health Act (OSHA).

Make certain the power source conforms to the pump voltage. Be sure all power is disconnected before installation.

The pump should be wired to an individual (dedicated) circuit, controlled with an UL/C-UL certified double pole switch rated at or above the fuse ampere indicated on the pump motor label.

On 115-volt AC pumps, the black wire lead is live common, the whites lead wire is neutral and the green/yellow is ground.

On the LF series 12 and 24 volt pumps the red lead is positive and should be connected to the battery plus (+) terminal. The black lead is ground and should be connected to the battery minus (-) terminal. Use T6 AWG wire minimum. Use a 5 AMP fuse to protect the system wiring and components.

Improper duty cycle and/or rapid start stop conditions caused by undersized spray nozzles will cause the internal thermal breaker (if equipped) to trip, or can cause premature motor failure due to excessive heat.



### WARNING



**DO NOT PUMP GASOLINE OR FLAMMABLE FLUIDS OR USE WHERE FLAMMABLE VAPORS ARE PRESENT.**

#### Dimensional Drawing

Inches (Millimeters)  
Dimensional tolerances ± 0.06 inches  
Consult factory if precise details are required.

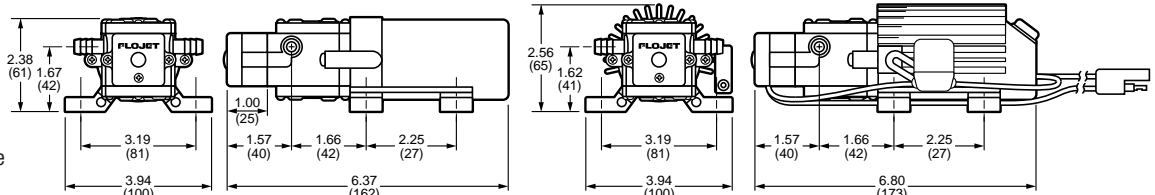

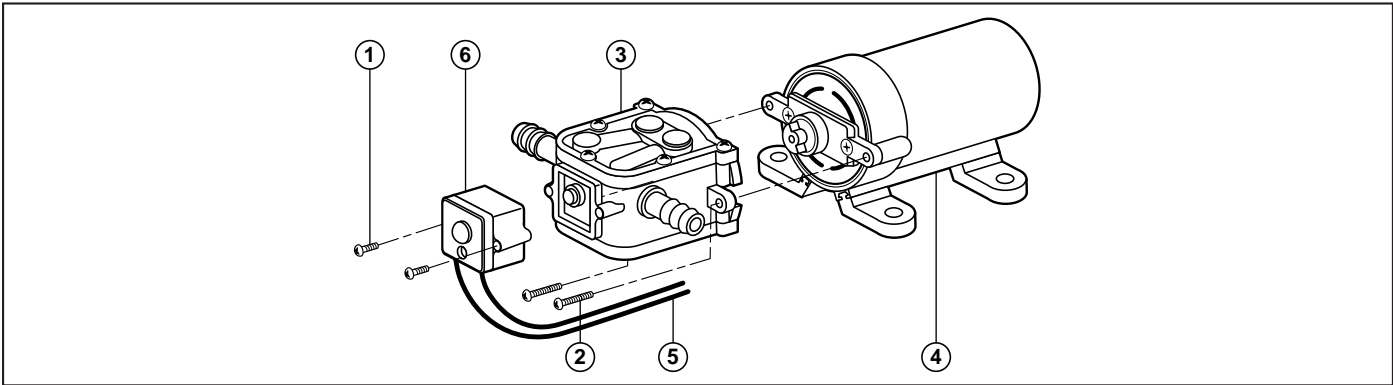

| KEY | DESCRIPTION         | KEY | DESCRIPTION     |
|-----|---------------------|-----|-----------------|
| 1   | Switch cover screws | 4   | Motor           |
| 2   | Pump head screws    | 5   | Lead wires      |
| 3   | Pump head           | 6   | Pressure switch |

### Disassemble

#### Pump Head

- 1 Take precautions to prevent injury due to chemical contact during maintenance.
2. Flush pump with water or neutralizing agent before servicing if the pump has been used to transport chemicals.
3. Disconnect the power to the pump motor.
4. Remove the pressure switch cover by removing the single screw (1) from pressure switch and remove switch cover.
5. Remove wires (5) from pressure switch by gently sliding female spade terminals away from the male spade connectors.
6. Remove two screws (2) from front of pump head.
7. Slide pump head (3) away from motor (4) assembly.

### Reassembly

#### Pump head (3) to Motor (4).

1. Assemble the pump head (3) to motor (4) aligning screws tabs.
2. Install screws (2) and tighten to 15 Inch ounces of torque.
3. Reconnect wires (5) to pressures switch. Wires can be connected can be connected to either terminal of the pressure switch.
4. Install the pressure switch cover with screw (1).
5. Reconnect pump to liquid source.
6. Reconnect pump to power source.
7. Allow pump to prime with discharge line or spray valve open.
8. Check for leaks in discharge system.

### Troubleshooting

#### Failure to Prime - Motor operates, but no pump discharge

- Restricted intake or discharge line. Open all line valves, check for "jammed" check valves, and clean clogged lines.
- Air leak in intake line.
- Punctured pump diaphragm.
- Defective pump check valve.
- Crack in pump housing.

• Debris in check valves.

#### Motor Fails to Turn On

- Pump or equipment not plugged in electrically.
- Loose wiring connection.
- Pressure switch failure.
- Defective motor or rectifier.
- Frozen cam/bearing.

#### Pump Fails to Turn Off after Discharge valves are Closed

- Depletion of available liquid supply.
- Punctured pump diaphragm.
- Discharge line leak.
- Defective pressure switch.
- Insufficient voltage to pump.
- Debris in check valves.

#### Low Flow and Pressure

- Air leak at pump intake.
- Accumulation of debris inside pump and plumbing.

- Worn pump bearing (excessive noise).
- Punctured pump diaphragm.
- Defective rectifier or motor.
- Insufficient voltage to pump.

#### Pulsating Flow - Pump Cycling On and Off

- Restricted pump delivery. Check discharge lines, fittings, valves and spray nozzles for clogging or undersizing.

### Service Kits

Kits are readily available to repair standard LF series pumps. To insure that the correct kits are received the model number and all name plate data must be included with the order. Contact a FLOJET distributor or FLOJET directly to order the necessary repair kits.

### PRODUCT WARRANTY

Flojet warrants this product to be free of defects in material and/or workmanship for a period of one year after purchase by the customer from Flojet. During this one year warranty period, Flojet will at its option, at no charge to the customer, repair or replace this product if found defective, with a new or reconditioned product, but not to include costs of removal or installation. No product will be accepted for return without a return material authorization number. All return goods must be shipped with transportation charges prepaid. This is only a summary of our Limited Warranty. For a copy of our complete warranty, please request Form No. 100-101.

### RETURN PROCEDURE

Prior to returning any product to Flojet, call customer service for an authorization number. This number must be written on the outside of the shipping package. Place a note inside the package with an explanation regarding the reason for return as well as the authorization number. Include your name, address and phone number.

Flojet



U.S.A.  
Flojet  
20 Icon  
Foothill Ranch, CA 92610-3000  
Tel: (949) 859-4945

UNITED KINGDOM  
Jabsco/Flojet  
Bingley Road, Hoddesdon  
Hertfordshire EN11 0BU  
Tel: +44 (0) 1992 450145  
Fax: +44 (0) 1992 467132

CANADA  
Fluid Products Canada  
55 Royal Road  
Guelph, Ontario N1H 1T1  
Tel: (519) 821-1900  
Fax: (519) 821-2569

JAPAN  
NHK Jabsco Company Ltd.  
3-21-10, Shin-Yokohama  
Kohoku-Ku, Yokohama, 222  
Tel: 045-475-8906  
Fax: 045-475-8908

GERMANY  
Jabsco GmbH  
Oststrasse 28  
22844 Norderstedt  
Tel: +49-40-53 53 73-0  
Fax: +49-40-53 53 73-11